

SDA Series Compact Cylinder

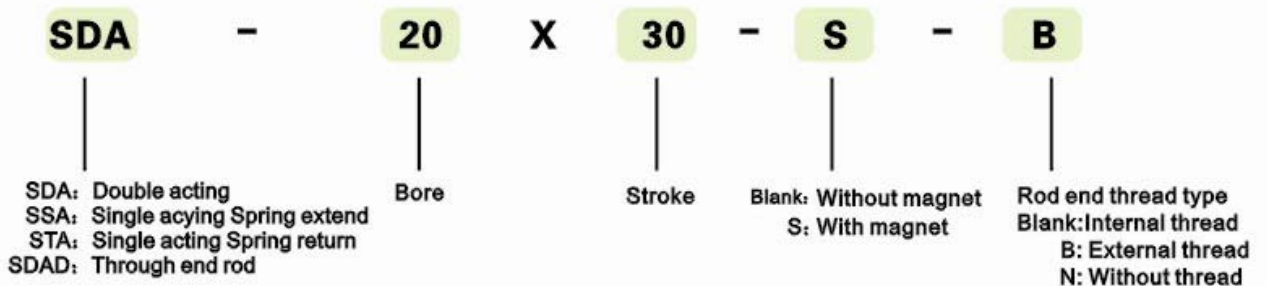

How to Order



Technical data

Bore (mm)		12	16	20	25	32	40	50	63	80	100	
Working medium		Filtered air										
Operating pressure range	Double acting	0.1~0.9MPa										
	Single acting	2~9					—					
Max. Pressure		1.05MPa										
Operating temperature range		0~70°C										
Operating Speed Range (mm/s)	Double acting	30~500					30~350			30~250		
	Single acting	100~500					—					
Port connection		M5 x 0.8			G1/8		G1/4			G3/8		

Stroke

Bore (mm)		12	16	20	25	32	40	50	63	80	100
Double Acting	Without magnet	5~60mm	5~65mm	5~85mm	5~90mm	100~110mm	5~90mm	100~130mm			
	With magnet	5~60mm	5~75mm	5~90mm	100mm	5~90mm	100~120mm				
Single Acting	Without magnet	5~30mm	5~30mm	5~30mm			5~30mm	—			
	With magnet	5~30mm	5~30mm	5~30mm			5~30mm	—			
Max.Stroke		60mm	100mm	120mm			130mm				

Dimensions(mm):

SDA12-16

SDA20-100

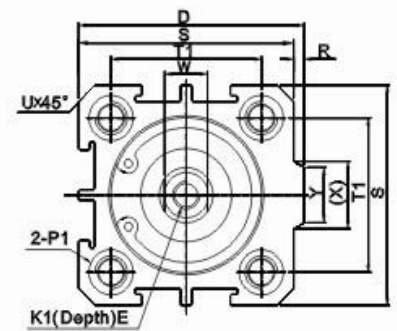
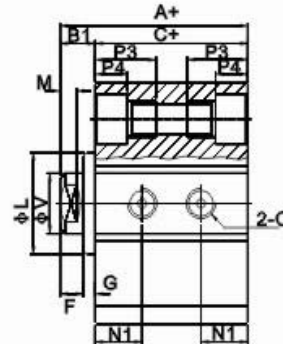
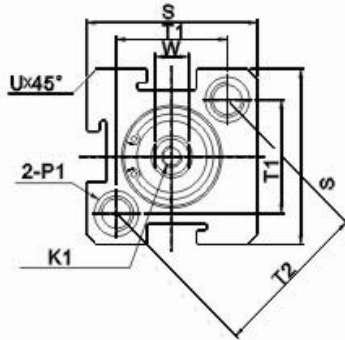
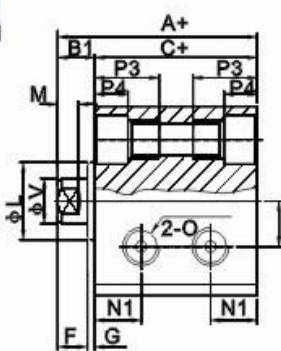

Type	Without magnet			With magnet			D	E	F	G	K1	L	M	N1	N3	O
	A	B1	C	A	B1	C										
12	22	5	17	32	5	27	-	6	4	1	M3 X 0.5	10.2	2.8	6.3	6	M5 X 0.8
16	24	5.5	18.5	34	5.5	28.5	-	6	4	1.5	M3 X 0.5	11	2.8	7.3	6.5	M5 X 0.8
20	25	5.5	19.5	35	5.5	29.5	36	8	4	1.5	M4 X 0.7	16	2.8	7.5	-	M5 X 0.8
25	27	6	21	37	6	34	42	10	4	2	M5 X 0.8	17	2.8	8	-	M5 X 0.8
32	31.5	7	24.5	41.5	7	34.5	50	12	4	3	M6 X 1	22	2.8	9	-	G1/8
40	33	7	26	43	7	36	58.5	12	4	3	M8 X 1.25	28	2.8	10	-	G1/8
50	37	9	28	47	9	38	71.5	15	5	4	M10 X 1.5	38	2.8	10.5	-	G1/4
63	41	9	32	51	9	42	84.5	15	5	4	M10 X 1.5	40	2.8	11.8	-	G1/4
80	52	11	41	62	11	51	104	15	6	5	M14 X 1.5	45	4	14.5	-	G3/8
100	63	12	51	73	12	61	124	18	7	5	M18 X 1.5	55	4	20.5	-	G3/8

Bore	P1			P3	P4	R	S	T1	T2	U	V	W	X	Y
12	Both side $\phi 6.5$	Cog M5 X 0.8	Through Hole: $\phi 4.2$	12	4.5	-	25	16.2	23	1.6	6	5	-	-
16	Both side $\phi 6.5$	Cog M5 X 0.8	Through Hole: $\phi 4.2$	12	4.5	-	29	19.8	28	1.6	6	5	-	-
20	Both side $\phi 6.5$	Cog M5 X 0.8	Through Hole: $\phi 4.2$	14	4.5	2	34	24	-	2.1	8	6	11.3	10
25	Both side $\phi 8.2$	Cog M6 X 1.0	Through Hole: $\phi 4.6$	15	5.5	2	40	28	-	3.1	10	8	12	10
32	Both side $\phi 8.2$	Cog M6 X 1.0	Through Hole: $\phi 4.6$	16	5.5	6	44	34	-	2.15	12	10	18.3	15
40	Both side $\phi 10$	Cog M8 X 1.25	Through Hole: $\phi 6.5$	20	7.5	6.5	52	40	-	2.25	16	14	21.3	16
50	Both side $\phi 11$	Cog M8 X 1.25	Through Hole: $\phi 6.5$	25	8.5	9.5	62	48	-	4.15	20	17	30	20
63	Both side $\phi 11$	Cog M8 X 1.25	Through Hole: $\phi 6.5$	25	8.5	9.5	75	60	-	3.15	20	17	28.7	20
80	Both side $\phi 14$	Cog M12 X 1.75	Through Hole: $\phi 9.2$	25	10.5	10	94	74	-	3.65	25	22	36	26
100	Both side $\phi 17.5$	Cog M12 X 1.75	Through Hole: $\phi 11.3$	30	13	10	114	90	-	3.65	32	27	35	26

Dimensions(mm):

STA12-16, spring return

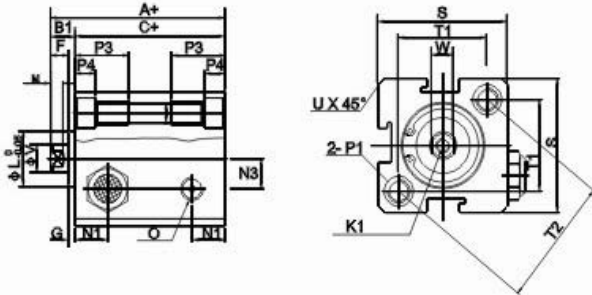

SSA12-16, spring extend

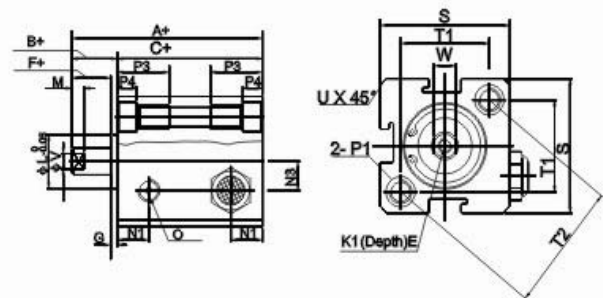

STA20-40, spring return

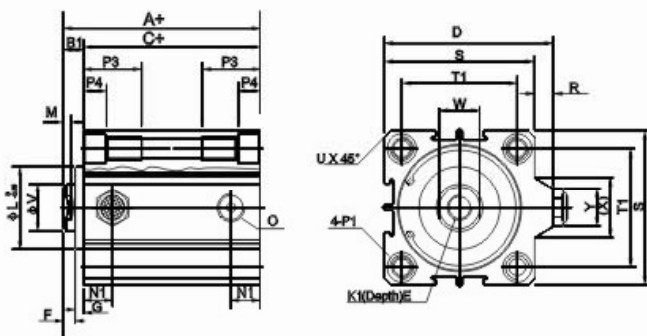

SSA20-40, spring extend

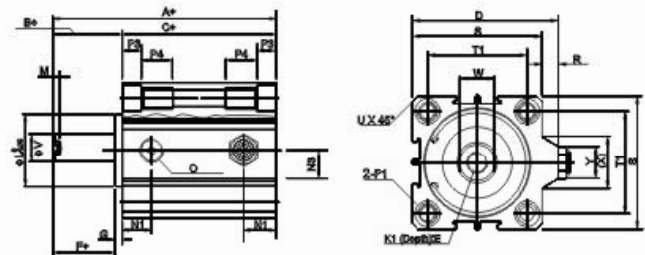

Type	Without magnet						With magnet						D	E	F	G	K1	L	M	N1	N3
	A		B1	C		A		B1	C												
	≤10	>10		≤10	>10	≤10	>10		≤10	>10											
12	32	42	5	27	37	42	52	5	37	47	-	6	4	1	M3x0.5	10.2	2.8	6.3	6		
16	34	44	5.5	28.5	38.5	44	54	5.5	38.5	48.5	-	6	4	1.5	M3x0.5	11	2.8	7.3	6.5		
20	35	45	5.5	29.5	39.5	45	55	5.5	39.5	49.5	36	8	4	1.5	M4x0.7	16	2.8	7.5	-		
25	37	47	6	34	41	47	57	6	41	51	42	10	4	2	M5x0.8	17	2.8	8	-		
32	41.5	51.5	7	34.5	44.5	51.5	61.5	7	44.5	54.5	50	12	4	3	M6x1	22	2.8	9	-		
40	43	53	7	36	46	53	63	7	46	56	58.5	12	4	3	M8x1.25	28	2.8	10	-		

Bore	O	P1			P3	P4	R	S	T1	T2	U	V	W	X	Y
12	M5 X 0.8	Both side φ6.5	Cog M5 X 0.8	Through Hole: φ4.2	12	4.5	-	25	16.2	23	1.6	6	5	-	-
16	M5 X 0.8	Both side φ6.5	Cog M5 X 0.8	Through Hole: φ4.2	12	4.5	-	29	19.8	28	1.6	6	5	-	-
20	M5 X 0.8	Both side φ6.5	Cog M5 X 0.8	Through Hole: φ4.2	14	4.5	2	34	24	-	2.1	8	6	11.3	10
25	M5 X 0.8	Both side φ8.2	Cog M6 X 1.0	Through Hole: φ4.6	15	5.5	2	40	28	-	3.1	10	8	12	10
32	G1/8	Both side φ8.2	Cog M6 X 1.0	Through Hole: φ4.6	16	5.5	6	44	34	-	2.15	12	10	18.3	15
40	G1/8	Both side φ10	Cog M8 X 1.25	Through Hole: φ8.5	20	7.5	6.5	52	40	-	2.25	16	14	21.3	16



Dimensions(mm)

Male threaded piston rod end

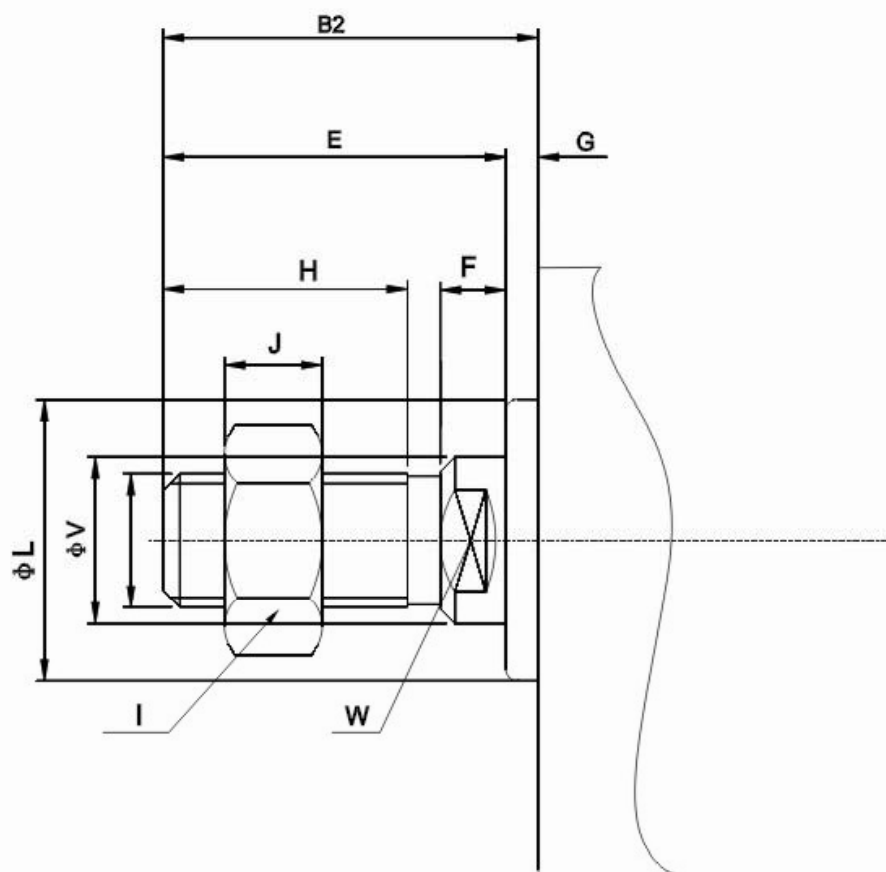

Model	B2	E	F	G	H	I	J	K2	L	M	V	W
12	17	16	4	1	10	8	4	M5 X 0.8	10.2	2.8	6	5
16	17.5	16	4	1.5	10	8	4	M5 X 0.8	11	2.8	6	5
20	20.5	19	4	1.5	13	10	5	M6 X 1.0	16	2.8	8	6
25	23	21	4	2	15	12	6	M10 X 1.25	17	2.8	10	8
32	25	22	4	3	15	17	6	M14 X 1.5	22	2.8	12	10
40	35	32	4	3	25	19	8	M18 X 1.5	28	2.8	16	14
50	37	33	5	4	25	27	11	M18 X 1.5	38	2.8	20	17
63	37	33	5	4	25	27	11	M22 X 1.5	40	2.8	20	17
80	44	39	6	5	30	32	13	M22 X 1.5	45	4	25	22
100	50	45	7	5	35	36	13	M26 X 1.5	55	4	32	27